

# TYPE SU-41

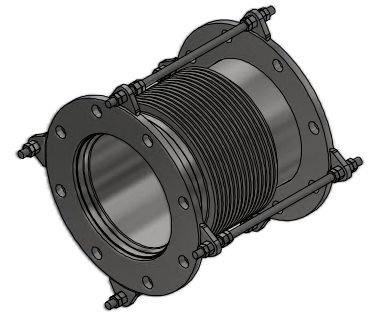
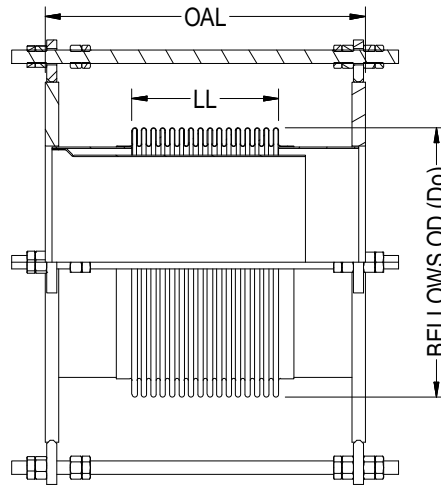

ISOMETRIC VIEW

PIPE SIZE	BELLOWS OD (Do)	LIVE LENGTH (LL)	OVERALL LENGTH (OAL)
2	3.10	2.00	6.00
2	3.10	6.00	12.00
2-1/2	3.70	2.00	6.00
2-1/2	3.70	6.00	12.00
3	4.40	2.00	6.00
3	4.40	6.00	12.00
4	5.36	2.50	6.00
4	5.36	5.50	12.00
4	5.15	9.00	18.00
5	6.70	3.00	8.00
5	6.55	5.50	12.00
6	7.70	3.00	8.00
6	7.63	5.50	12.00
8	10.10	4.13	8.00
8	10.10	5.50	12.00
10	12.00	2.00	4.00
10	12.10	4.00	8.00
10	12.00	5.50	12.00
12	14.80	6.00	12.00
12	14.00	8.00	18.00
12	14.30	13.50	23.00
14	16.30	1.25	4.50
14	16.00	4.50	12.00

PIPE SIZE	BELLOWS OD (Do)	LIVE LENGTH (LL)	OVERALL LENGTH (OAL)
14	15.75	13.00	23.00
16	17.75	8.00	16.00
16	17.75	13.50	23.00
18	20.20	4.00	12.00
18	20.20	10.00	18.00
18	20.20	13.00	23.00
20	22.00	4.00	6.00
20	22.25	4.50	12.00
20	21.91	9.00	18.00
20	21.75	13.50	23.00
24	25.90	4.50	12.00
24	26.00	12.00	18.00
24	26.00	13.00	22.00
24	25.75	20.00	36.00
26	27.75	14.00	22.00
26	27.75	18.00	30.00
28	30.70	12.50	24.00
30	31.75	4.00	10.00
30	32.00	8.00	16.00
30	31.75	18.00	29.00
36	38.25	2.50	7.00
36	38.40	6.00	12.00
36	37.97	9.00	17.00

**NOTES:**

1. FLANGES ARE OF 150# PLT-1/2" THK. (ANSI B16.5 BOLT PATTERN)
2. FLANGE MATERIAL: ASTM A-36. FOR OTHER OPTIONAL MATERIAL PLEASE CONTACT BSI.
3. OAL IS BASED ON LIVE LENGTH. FOR OTHER OPTIONAL LENGTH PLEASE PROVIDE THEM IN THE SPECIFICATION SHEET.
4. BELLOWS MATERIAL: ASTM A-240 GRADE 321. OTHER MATERIALS (STAINLESS STEEL, NICKEL ALLOYS ETC.) ARE AVAILABLE ON REQUEST.
5. AVAILABLE IN 1 PLY, 2 PLY (STD) OR 3 PLY DESIGNS.
6. SPECIFY DESIGN/OPERATING TEMPERATURE & PRESSURE IN PAGE 2.
7. FOR MOVEMENTS AND LIFE CYCLE REFER TO BELLOWS CATALOG OR CONTACT BSI ENGINEERING.

				 <b>Bellows Systems</b>		<b>BELLOWS SYSTEMS, INC.</b> Houston, TX <a href="http://www.bellows-systems.com">www.bellows-systems.com</a>	
						SINGLE EXPANSION JOINT STD. TYPE SU-41 W/ 150# LW PLT FLG, LINER & CONTROL ROD	
REV.	DESCRIPTION	DATE:	BY:	CHKD:	APPD:	CAGE CODE: 22727	
F	UPDATED TYPE NO.	11/8/2023	UG				
E	UPDATED NOTES	09/12/2023	UG				
THIS DRAWING AND ALL OF THE INFORMATION HEREIN ARE THE SOLE PROPERTY OF BELLOWS SYSTEMS, INC. AND MAY NOT BE REPRODUCED OR DISTRIBUTED WITHOUT THE EXPRESS WRITTEN CONSENT OF BELLOWS SYSTEMS, INC. (BSI).				SHEET SIZE: 8.5" x 11"	DRAWN BY: U GULATI	DATE: 03/08/2023	SCALE: AS SHOWN
						DRAWING NUMBER: 130-CAT-0041	SHEET#: 1 OF 2
						REV. F	

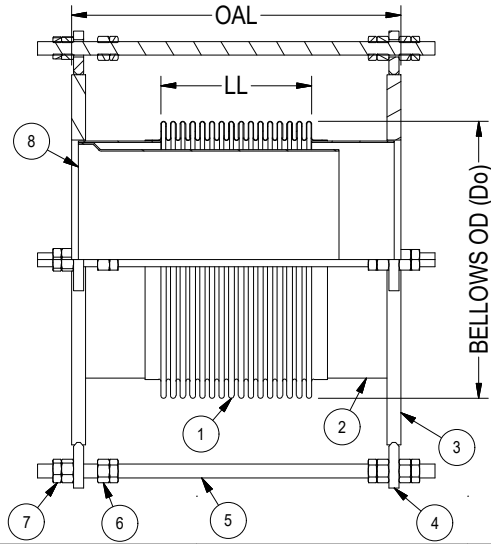

		1	2	3	4
<b>DIM.:</b>	PIPE/ NOMINAL SIZE:				
	OVERALL LENGTH (OAL):				
<b>DESIGN:</b>	PRESSURE:				
	TEMPERATURE:				
<b>MOV. &amp; LIFE CYLS:</b>	AXIAL COMPRESSION:				
	AXIAL EXPANSION:				
	LATERAL:				
	ANGULAR:				
	NO. OF CYCLES:				
<b>MAT'L'S:</b>	① BELLOWS:				
	② WELD NECK:				
	③ FLANGE:				
	④ LUG:				
	⑤ CONTROL ROD:				
	⑥ HEX NUTS:				
	⑦ HEX JAM NUTS:				
	⑧ LINER:				
<b>DESIGN CODES/STANDARDS:</b> (EJMA/ ASME SECT VII DIV 1/ ASME B 31.1/ ASME B 31.3)					
<b>APPLICATION NOTES:</b>					
<b>QUANTITY:</b>					

**OPTIONAL FEATURES:**

1. WITHOUT FLOW LINER (SEE TYPE-01).
2. FLOW LINER (SEE TYPE-21).
3. EXTERNAL COVER.

				 <b>Bellows Systems</b>		<b>BELLOWS SYSTEMS, INC.</b> Houston, TX <a href="http://www.bellows-systems.com">www.bellows-systems.com</a>	
						SINGLE EXPANSION JOINT TYPE SU-41 SPECIFICATION SHEET	
F	UPDATED TYPE NO.	11/8/2023	UG				
E	UPDATED NOTES	09/12/2023	UG				
REV.	DESCRIPTION	DATE:	BY:	CHKD:	APPD:	CAGE CODE: 22727	
THIS DRAWING AND ALL OF THE INFORMATION HEREIN ARE THE SOLE PROPERTY OF BELLOWS SYSTEMS, INC. AND MAY NOT BE REPRODUCED OR DISTRIBUTED WITHOUT THE EXPRESS WRITTEN CONSENT OF BELLOWS SYSTEMS, INC. (BSI).				SHEET SIZE: 8.5" x 11"	DRAWN BY: U GULATI	DATE: 03/08/2023	SCALE: AS SHOWN
						DRAWING NUMBER: 130-CAT-0041	SHEET#: 2 OF 2
						REV. F	